

# WINEKEEPER

Keeping good company since 1983



## MONTEREY / SONOMA

Operating Instructions Manual

*Auto Defrost Refrigerators*

# Table of Contents

<b>Setting Up Your Unit</b> <i>Unpacking, installing faucets, installing the regulator, and connecting wine bottles.</i>	<b>3</b>
<b>Getting to Know Your WineKeeper™</b> <i>Temperature zones, lights, cords, hoses, knobs, and switches.</i>	<b>5</b>
<b>Operating Your Unit</b> <i>Changing bottles and gas cylinders.</i>	<b>6</b>
<b>Cleaning Your Unit</b>	<b>7</b>
<b>Troubleshooting</b> <i>Finding a nitrogen leak, frost build-up, or making temperature adjustments.</i>	<b>8</b>
<b>FAQs</b>	<b>10</b>
<b>Technical Information</b> <i>System diagram and wiring diagram.</i>	<b>13</b>



Keeping good company since 1983

531 Mercantile Drive  
Cotati, CA 94931

1.855.511.5113  
info@winekeeper.com  
www.winekeeper.com

# Unpacking

While unpacking your unit, please check to make sure that all parts are included and undamaged. Please call WineKeeper at 855.511.5113 if there are any problems. YOU MUST REPORT damage immediately and missing parts within 7 days of receiving your unit.

These parts are included with your unit:

- Appropriate number of faucets for your unit
- Regulator (for use with refillable nitrogen or argon cylinder)
- Cleaning kit
- Instructions

## Setting Up Your Unit

Your WineKeeper wine dispensing unit must be installed on a flat, level surface with vented space of at least 3" behind, 1" on the sides, and 12" above the unit for proper ventilation. Once your unit is properly located, attach the faucets. Taking care to align the threads properly, place the faucet on the thru-wall and tighten the wing nut.

You may now plug the units' power cord into 110 volt grounded electrical outlets. Be sure to plug in all electrical cords:

- 4-bottle units = 1 plug
- 8-bottle units = 2 plugs
- 12-bottle units = 3 plugs

An 8 foot gas supply line is included with your unit. The supply line includes a quick connect fitting that connects to the regulator supplied with your unit. **USING A REGULATOR OTHER THAN THE ONE SUPPLIED WILL VOID THE WARRANTY.** Your nitrogen/argon cylinder can be placed anywhere convenient—vertical or horizontal.

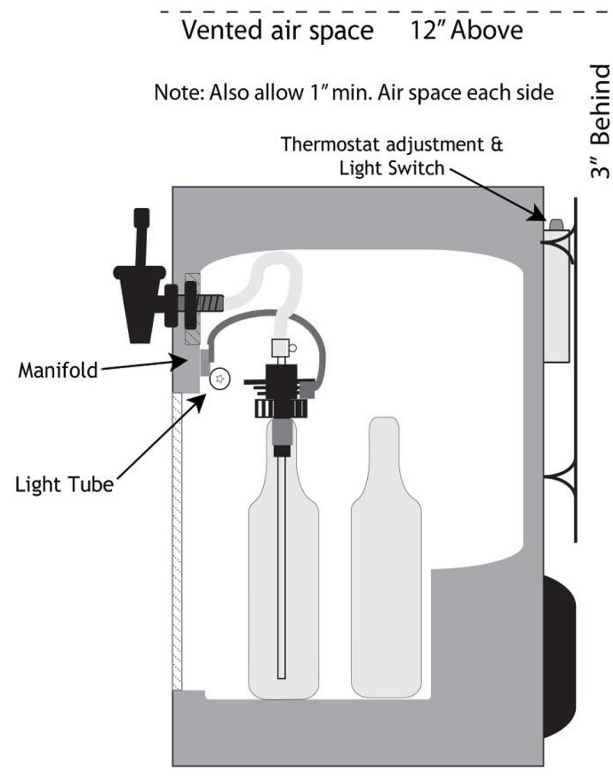

Side view

**DO NOT TAMPER WITH OR REMOVE THE QUICK-DISCONNECT TO COUPLE YOUR GAS SUPPLY LINE AND REGULATOR, THIS WILL ALSO VOID THE WARRANTY.**

Hand tighten the supplied regulator to your nitrogen/argon cylinder, do not use a wrench. Do not connect the gas line to the regulator at this time. Open the gas cylinder valve (turn the valve counter-clockwise to open.) The gas pressure from the cylinder will seal the regulator in place. The gauge on the regulator should read approx. 1800 lbs. for an aluminum cylinder, and 2200 lbs. for a steel cylinder, when full.

You must now bleed the air from the system. With all the pinch clamps open, attach the gas supply line quick connect fitting to the regulator fitting. Be sure the small metal lever on the gas supply line fitting is in the down position. When the gas begins to flow through the lines and out the stopper assemblies, move down the unit closing off all the pinch clamps. You are now ready to connect wine bottles.

## How to Attach Wine Bottles to Your Machine

1. Place the stopper assembly into the wine bottle. (Attach FULL wine bottles ONLY.)
2. While holding the stopper so that the latex seal is just at the lip of the bottle opening, open the pinch clamp for 2 seconds. This will displace the air from the bottleneck.
3. Close off the pinch clamp, and insert the stopper all the way into the bottle.
4. Hold the stopper assembly with one hand and tighten the knurled thumbwheel clockwise with the other hand until gently snug. Turn the thumbwheel  $\frac{1}{4}$  to  $\frac{1}{2}$  of a turn further. **DO NOT OVER-TIGHTEN THE THUMBWHEEL.** If the thumbwheel “pops” while turning, you have over-tightened it. The best seal is obtained with a dry bottleneck and latex seal. **OVER-TIGHTENING** will damage the stopper.

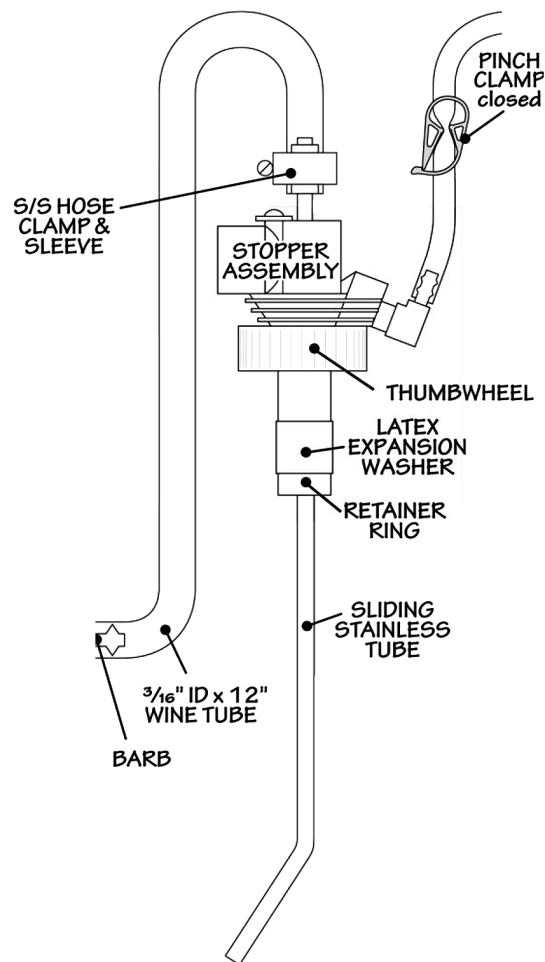

5. Adjust the sliding stainless steel tube for proper bottle depth. The tube may be placed all the way to the bottom for white wines, and slightly raised off the bottom for red wines with sediment.

6. Open all pinch clamps and pull the faucet handle to produce a drop of wine from each faucet.  
This removes the air trapped between the wine in the tube and the faucet tip.
7. Dispense wine by pulling the faucet handle completely forward to achieve a clean pour.

**Note:** WineKeeper has preset your unit to hold white wine at 44°-45° F and red wine at 62° -64° F. After initial set up is complete, let your unit run for 24 hours before attempting any temperature adjustment. (See “*Temperature Adjustment*” and “*FAQs*” #3, #4, #5 and #6, before adjusting temperature).

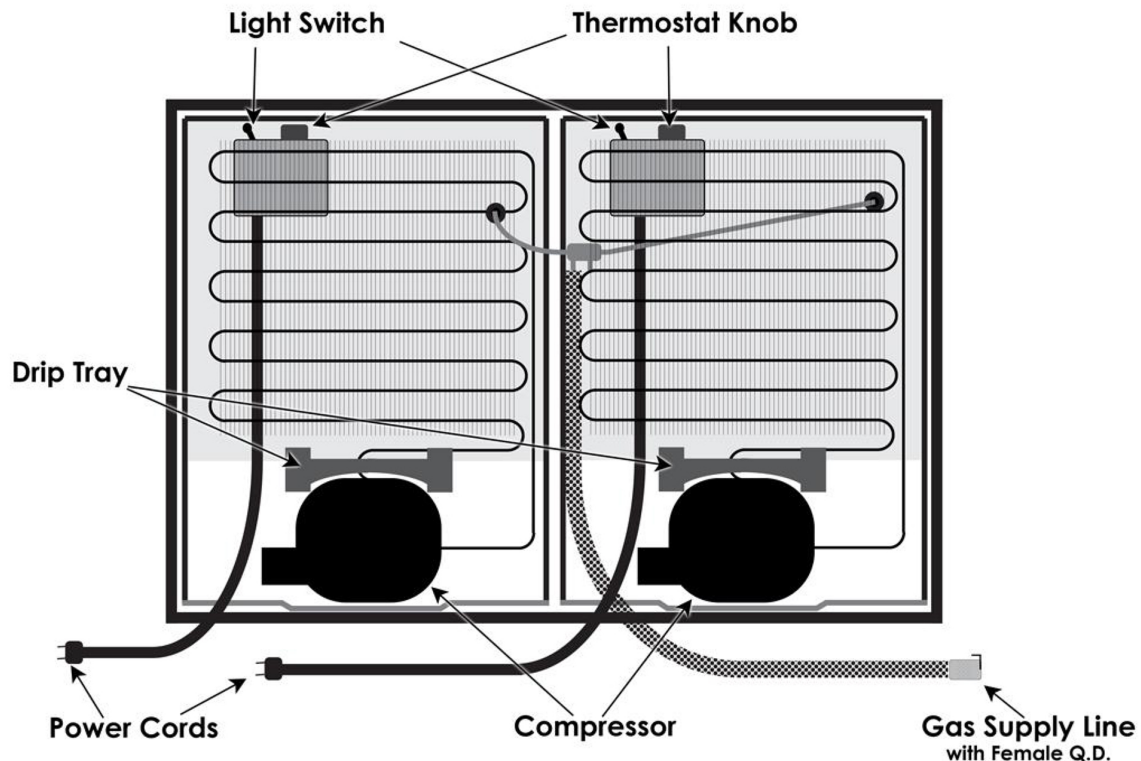

## Getting to Know Your WineKeeper

This unit uses pressurized nitrogen or argon gas to dispense and preserve wine from within a temperature-controlled zone. Your unit may have up to three temperature zones, which can be controlled by the grey knobs on the back, see diagram.

These units are illuminated by a series of light tubes installed on the inside of the unit. Each zone has its own light tube that is controlled by a toggle switch on the back of the unit next to the thermostat knob.

Depending on which model you have, your unit may have up to three power cords exiting the back of the machine. **ALL POWER CORDS MUST BE ATTACHED FOR THE UNIT TO WORK PROPERLY.**

Your unit uses a nitrogen or argon cylinder (not included) located remotely and connected to your unit by an 8-foot long braided hose that has a metal quick disconnect fitting on the end. This hose exits the rear of the unit at the bottom next to the power cords.

**CAUTION: Risk of Electric Shock !**  
 This equipment may have two or more power supply cords. Unplug all cords before moving or servicing this equipment.

## Operating Your Unit

### Changing bottles

1. Pinch off the nitrogen clamp.
2. Loosen the thumbwheel.
3. Remove the empty bottle, replace with full bottle.
4. Follow steps 1-7 listed in “Setting Up Your Unit”.

### Changing gas cylinder

1. Turn cylinder valve to the off position (clockwise) and disconnect the supply hose from the regulator by depressing the small metal lever. Your system will remain pressurized.
2. Depress the tip of the quick-connect fitting on the regulator, relieving the pressure in the regulator, so that you may loosen the hand nut. Replace the cylinder and attach the regulator, hand tighten the regulator nut onto the new full cylinder and open the cylinder valve. A full aluminum cylinder will read 1800 lbs., a steel cylinder will read 2200 lbs.
3. Depress the tip of the quick-connect fitting on the regulator for two seconds to displace air from the regulator.
4. Reconnect the supply hose to the regulator.

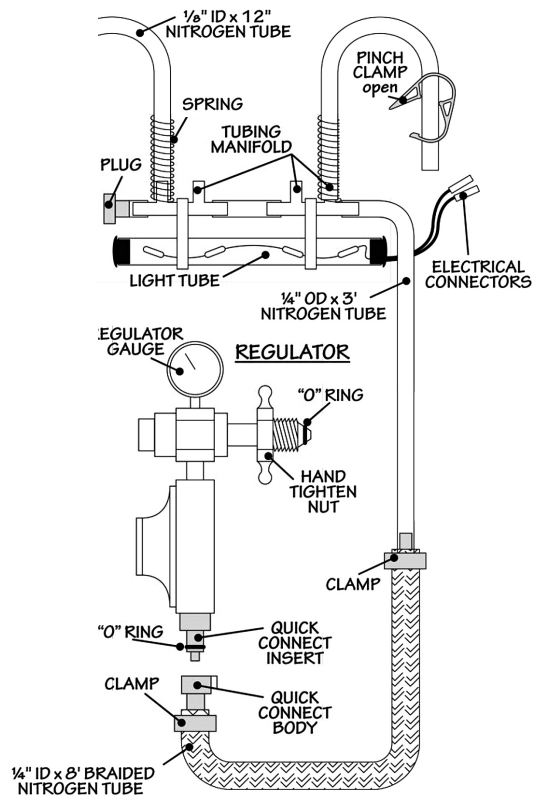

Your system is now ready for use. There is no need to bleed the system, as the supply hose quick-connect has a shut off valve which holds gas pressure to the wine bottles during the cylinder change out.

# Cleaning Your Unit

When used correctly, your WineKeeper system prevents the oxidation process that causes wine to spoil. Lack of proper maintenance will eliminate most of the benefits of your WineKeeper. Indications that your system needs cleaning include wine with a cloudy look and /or an odd taste. We recommend that you clean your system once a month or as needed.

## Standard Cleaning Process

1. Close off the nitrogen pinch clamps.
2. Loosen the stopper assemblies in each bottle to release gas pressure.
3. Pull the handle on each faucet (with a glass below) to drain wine from each faucet and tube. Remove the wine bottles. Do not place these used bottles back on the unit after you have completed the cleaning process, these wines should be hand poured.
4. Mix the Wine Line Cleaner (WLC) solution with water as per the instructions printed on the container (additional cleaning supplies are available from WineKeeper).
5. Pour this mixture into clean empty wine bottles (3 - 4 ounces is sufficient).
6. Replace and seal the stopper assemblies in each bottle then open the pinch clamps.
7. Pour off a small amount of the liquid. Allow solution to remain in the wine tubes for 10 minutes. Dispense the remaining solution through the system.
8. Rinse by running one full bottle of hot water through the system.
9. Mix ChlorTab Sanitizer solution per instructions and repeat steps 5, 6 & 7 allowing three minutes of contact.
10. Rinse with hot water.
11. Remove the faucet assembly from the thru-wall.
12. Unscrew the bonnet from the black funnel shaped portion (faucet body) of the faucet assembly.
13. Remove the seat cup from the stem. Clean the seat cup and the faucet body in the sanitizer. Rinse with warm water. **(DO NOT USE SOAP!)** Dry and re-assemble the faucet assembly.

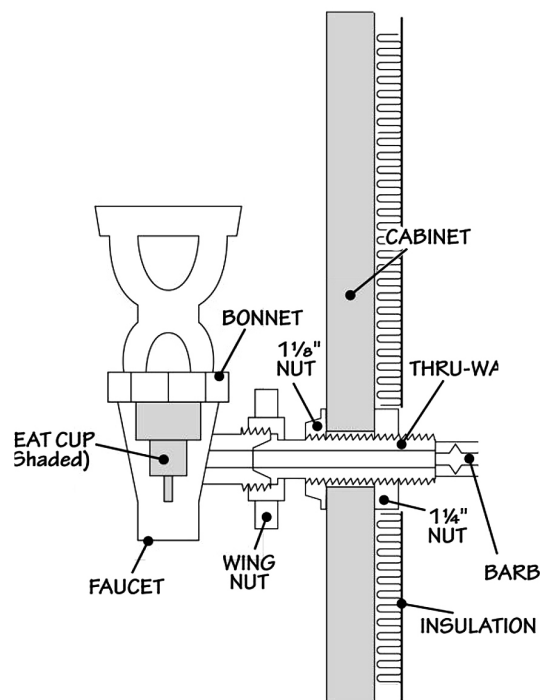

14. Use the supplied bottle-brush to scrub inside the thru-wall and upper portion of the wine tube. Use the smaller bottle-brush to clean inside the stainless steel siphon tube.
15. Re-install the faucet assembly onto the thru-wall.
16. Rinse out the empty wine bottles and fill completely with clean hot water. Dispense 1 full bottle of water through each faucet assembly. Drain all water from the faucet assemblies and wine tubes.
17. Your unit is now ready for use. Place only full bottles of wine on your WineKeeper, do not reattach the bottles you removed for the cleaning process.

**Note:** Never leave a stopper assembly outside of a bottle. Air will come in contact with the wine inside the wine tube and faucet assembly, beginning the oxidation process and possibly exposing the system to bacteria.

## **Cabinet Exterior**

**Wood Units:** All WineKeeper wooden cabinets are finished with a durable catalyzed finish. These cabinets can be cleaned with a soft cloth and small amount of warm soapy water. Avoid using excessive amounts of water, as this may cause the finish to peel or flake over time. Do not use abrasive cleaners or products containing harsh solvents.

**Plastic and Metal Laminates including Stainless Steel:** These products tend to resist most solvent-based cleaners, so it is recommended that their use be limited. Warm soapy water is the recommended cleaning method for these units. A number of specialty products designed to clean these types of materials are readily available through kitchen and restaurant supply firms, but do not use abrasive cleaners.

## **Cabinet Interior / Glass**

All WineKeeper interiors can be cleaned with warm soapy water. DO NOT USE any abrasive cleaners. Stubborn stains may need to be cleaned with products similar to 409™. These products MUST NOT contain solvents, as this will seriously mar the interior surfaces! The glass on the unit can be cleaned with any product similar to Windex™. Silicone sprayed into each door track will assist door operation. Sliding glass doors can be removed from the cabinet by first lifting the glass upwards, then pulling the bottom of the glass towards you, and down. (Make sure that all glass doors are replaced in the correct track. Failure to do so may result in a change of interior temperatures and refrigeration efficiency).

# **Troubleshooting**

If you are experiencing problems with your WineKeeper, please read over the information included in this manual before calling us at 855.511.5113.



## Finding a Nitrogen Leak

### Checking Supply Hose and Tubing

Visually check all tubes for cracks or holes.

**Checking the Regulator** (must be original WineKeeper regulator for safety and performance):

1. Disconnect the quick-connect fitting on the supply tube where it joins the regulator.
2. Turn on the cylinder. (Make a note of the pressure registered on the regulator gauge).
3. Turn off the cylinder.
4. Wait 20-30 minutes, if the pressure registered on the regulator has dropped, the problem is in the regulator.
5. Use soapy water to find the leak or return the regulator to WineKeeper for repair.
6. If leak is not in the regulator, or the regulator leak has been repaired, continue.

**Checking the system** (For this test, the WineKeeper should be connected to wine bottles with 2-3 ounces of liquid for best results.)

1. Reconnect the supply line and open the cylinder valve.
2. Leave the valve open for 30 seconds to completely pressurize the system.
3. Close off the nitrogen pinch clamps. Stopper assemblies must be in the wine bottles and tightened down at this time.
4. Turn off the cylinder valve and note the pressure on the regulator's gauge.
5. Leave the unit undisturbed for 20 minutes.
6. If the pressure drops, your problem is in the supply line between the regulator and the pinch clamps. If the pressure does not drop, continue to step #7. Check the supply tubes where they pass through the cabinet for holes, cracks, or chafing.
7. While observing the cylinder contents on the regulator's pressure gauge, open and close each pinch clamp one at a time. Stop if you see the pressure gauge drop while the pinch clamp is open, because you have found a problem. It could be that the stopper-assembly has not been tightened into the bottle correctly, that the tube below the pinch clamp has a hole, or that the latex ring has become excessively worn. Address each of these possibilities and repeat these steps if necessary. If no leak is found, human error is suspected as the cause of the leak.
8. If this problem continues contact WineKeeper for additional help.

**Note:** If the stopper assembly appears to be leaking wine, tighten the stainless steel hose clamp that connects the clear wine tube to the stainless steel tube right above the stopper assembly. Look for a leak anywhere in the wine tube or the barb on the back of the thru-wall inside the cabinet. Remember that your WineKeeper should be cleaned at least once a month.

## **Frost Build Up / Temperature Adjustment**

All refrigerators may need periodic defrosting, especially units that have been operating with their doors ajar. (Always check that the doors are closed correctly!) Simply place a towel behind the wine bottles, leave the doors open, and turn the refrigerators off. We suggest that the unit be unplugged for the defrosting process as opposed to turning the thermostat to the off position while defrosting. This method saves you the trouble of having to re-adjust the temperature when you re-start the unit. **NEVER USE ANY SHARP TOOL TO SPEED UP THE DE-ICING PROCESS!** To adjust the temperature on these units you will need to access the back of your cabinet. The grey thermostat knobs are located on top of the silver metal electrical cover box on the rear upper right corner of each refrigerator when viewed from the front. Turning the knob on these units clockwise will cause the unit to run colder (never turn to max); turning it counter-clockwise will cause the unit to run warmer. A 1/16th turn will change the temperature approximately 3° F. Allow a minimum of 2 hours between temperature adjustments to allow unit temperature to stabilize.

**Note:** The thermometer reads air temperature. The air temperature will fluctuate 4°- 5° F as the refrigerator cycles on and off. The product temperature remains at the mid range of this fluctuation.

## **Frequently Asked Questions**

### **1. How do I change a light tube?**

Light tubes are held in place by two nylon clamps, and are connected using male/female plug connections on each of the wires. First unplug the unit that you are working on (there maybe more than one electrical cord on your unit). Carefully separate the blue male connector from the blue female connector on each electrical wire. **DO NOT PULL ON THE WIRE TO SEPARATE PLUGS.** You may use pliers if needed. Next, slide disconnected light tube to the left until it comes out of one the retaining clamps, then slide the light tube to the right until it drops free. Reverse process to re- install.

### **2. Where can I find the light switch?**

The light switch for these models is located at the upper right corner on the back of each refrigerator when viewed from the front of your cabinet. It is on top of the rectangular metal cover box.

### **3. What temperature should my white wine / standard thermostat be set to?**

The white wine thermostat has an operational range of approximately 42° - 48° F, and WineKeeper has preset it to 44° - 45° F. If a warmer temperature is required, an optional dual range thermostat can be installed. Dual range thermostats have a range of 46° - 68° F.

### **4. What temperature should my red / dual range thermostat be set to?**

The dual range thermostat has an operational range of approximately 46° - 68° F, WineKeeper has preset it to 62° - 64° F. Attempting to adjust the thermostat beyond the operational range will either lock the refrigerator in the full on or full off position. A full on position will cause the unit to ice up and bypass the defrost cycle.

**5. How do I tell the difference between a dual range thermostat and a white wine / standard thermostat?**

Dual range thermostats have a sliver tube with a bulb about 4" in length fastened to the back wall on the inside of the bottle compartment. A white wine thermostat will have a small white tube inserted into a white rectangular clip attached to the cold plate.

**6. Why is my unit having a cooling problem?**

Cooling problems for cold plate style refrigerators generally fall into four categories:

1. Inadequate ventilation to the rear coils.
2. Thermostat failure or maladjustment.
3. Ice builds up in the cold plate.
4. Compressor failure or refrigerant leak.

New units are factory set for 44° - 45° F for white wines, and 62° - 64° F for red wines. There is a different thermostat for white and red wines. Proper vented air space is 12" above, 3-6" behind, 1-2" each side. If your new unit has adequate ventilation, is running, but not getting cold, call WineKeeper for instructions. For older units, check and clean the rear coils, otherwise the same guidelines apply. Any unit that has been working properly, but is now failing to cool down, is possibly having an equipment failure, as opposed to a thermostat maladjustment or ventilation problems. Call WineKeeper for instructions.

**7. What kind of regular maintenance should I perform on my unit?**

Visually inspect the latex rings on each stopper assembly for wear or splits. Replace as needed. Inspect all O-rings on the inlet and outlet sides of the regulator and any quick disconnect fittings on your unit. Replace when showing signs of wear or cracking (silicone lubricant or mineral oil applied to these O-rings will increase their longevity). Clean all parts that come in contact with the wine every 4 weeks (see cleaning instructions). Replace the white pinch clamps as needed.

**8. How do I replace my stopper assembly?**

You must first be sure to pinch off the nitrogen pinch clamp and release pressure from the wine bottle, then remove the complete assembly from the cabinet by loosening the hose clamp using either a slotted screw driver or a 1/4" socket or nut driver. Pull the wine tube (with the hose clamp still connected) off of the stainless steel siphon tube that passes through the stopper assembly. Pull off the 1/4" O.D. nitrogen supply line from the brass fitting on the rear of the stopper assembly. (Before replacing this tube on the brass fitting later, you may need to cut off approximately 3/8" so that you will have a tight connection). Now that you have completely removed the stopper assembly from the cabinet, grab the stainless tube at the bottom where it is bent, and pull it out of the stopper assembly. Insert the stainless tube into the new stopper assembly, use a little water to lubricate the first 3"- 4". Simply reverse above steps to re-install.

**9. Which gas is better for my WineKeeper unit, nitrogen or argon?**

Nitrogen, which comprises approximately 80% of the air we breathe, is inert (it has no odor, taste or color, and displaces oxygen). Argon has similar properties, but is slightly heavier than air and tends to form a blanket between the surface of the wine and any air trapped in the bottle. Neither gas has any special properties, such as neutralizing or encapsulating oxygen. Oxygen is what causes wine to oxidize.

While argon has a slight advantage, its benefits are minimal due to its higher expense and lower availability. The only time argon out-performs nitrogen is when sparging an opened and poured bottle of fresh wine. Sparging is introducing a gas into a bottle to force out as much air as possible before re-corking it. Using argon in a properly used and maintained WineKeeper may slightly increase the wines useful life on the machine.

**10. How long will wine last on my WineKeeper™ unit?**

The length of time wine will remain fresh on your WineKeeper will vary based on a number of factors: temperature, wine age and wine type, and cleanliness of your machine. This makes it impossible to give a firm length of time. As a guideline you should expect wines to last approximately one to three weeks. Some wines, such as ports and sauternes, can remain sound for many weeks.

**11. Why does my wine appear to be cloudy or flakey?**

Cloudy or flakey wine may be a symptom of a dirty system and poor maintenance. Incorrect use of the system may also contribute to this condition. See "*Operating and Cleaning Instructions*".

**12. Why does my wine taste or smell bad?**

If your WineKeeper unit has been working correctly for some time, but now you are noticing a change in the wine, the problem is most likely due to poor maintenance and / or improper use. See: "*Cleaning Your WineKeeper*" and "*Set up Instructions*."

**13. Why is my wine not pouring from one or more of my faucets?**

If all of the faucets / stoppers appear to be not working at all, look at these problem areas:

- Nitrogen cylinder out of gas
- Nitrogen supply tube not connected to the regulator
- Nitrogen supply tube kinked or pinched
- All white plastic nitrogen pinch clamps are closed
- Stopper assemblies not tightened into neck of each bottle
- Nitrogen cylinder not opened
- Regulator failure

If one or two faucets/stoppers don't work, look at these problem areas:

- Stopper assemblies not tightened into neck of the wine bottle
- White plastic nitrogen pinch clamp closed
- Debris in bottom of stainless steel wine pick-up tube
- Kink or hole in supply line to stopper assembly

**14. Why is wine dripping from my faucet?**

Almost all cases of wine dripping from the faucet are caused from lack of cleaning, debris in the faucet, or the bonnet is cross-threaded and not screwed down completely. Disassemble the faucet and clean using warm water or Wine Line Cleaner. Check to make sure that the seat cup has no small cuts or tears. Reassemble the faucet, making sure that the bonnet is not cross-threaded.

# Technical Information

## WineKeeper System Diagram

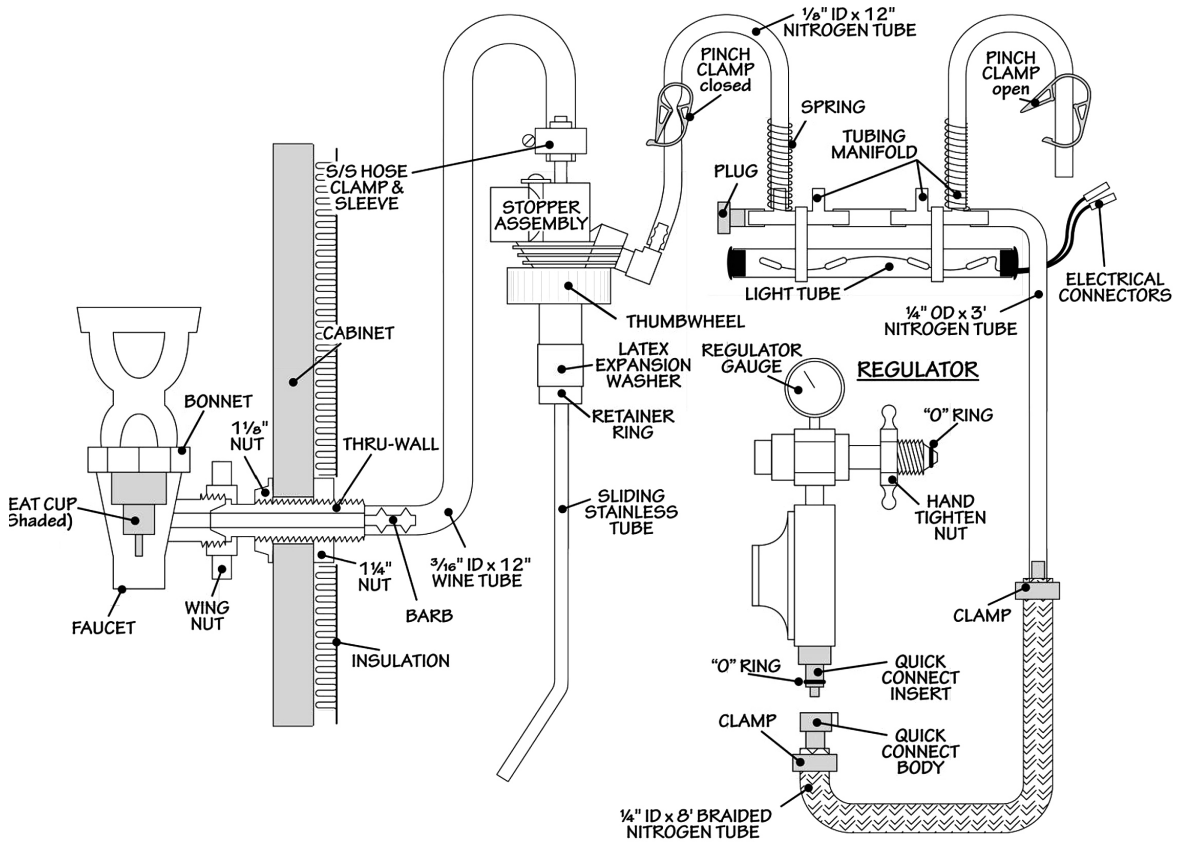

## Electrical Wiring Diagram

